

Kaiser. Performance counts.



**NEW
GENERATION**

S12 **S10**
ALLROAD

**KAISER MOBILE
WALKING EXCAVATORS**

PERFORMANCE AND EFFICIENCY

WHEN PERFORMANCE COUNTS

The latest generation of KAISER S10 and S12 mobile walking excavators again sets benchmarks in terms of performance and efficiency.

Evolution of the technology leader

Development of the S10 and S12 Allroad has been taken a step further in several areas. Core features include the optimised hydraulic power combined with the appropriate cooling system for particularly power-intensive applications as multifunctional carrier. Cutting-edge engine technologies with a wider choice of options and engine models provide ample power reserves and continue to set the benchmark in this tonnage class. In addition, working time has been extended by an increased tank capacity.

Stable – even in extreme terrain

This is where KAISER mobile walking excavators have always been the industry benchmark. New: greater maximum wheel leg mobility, which increases wading depth to 2.45 metres.

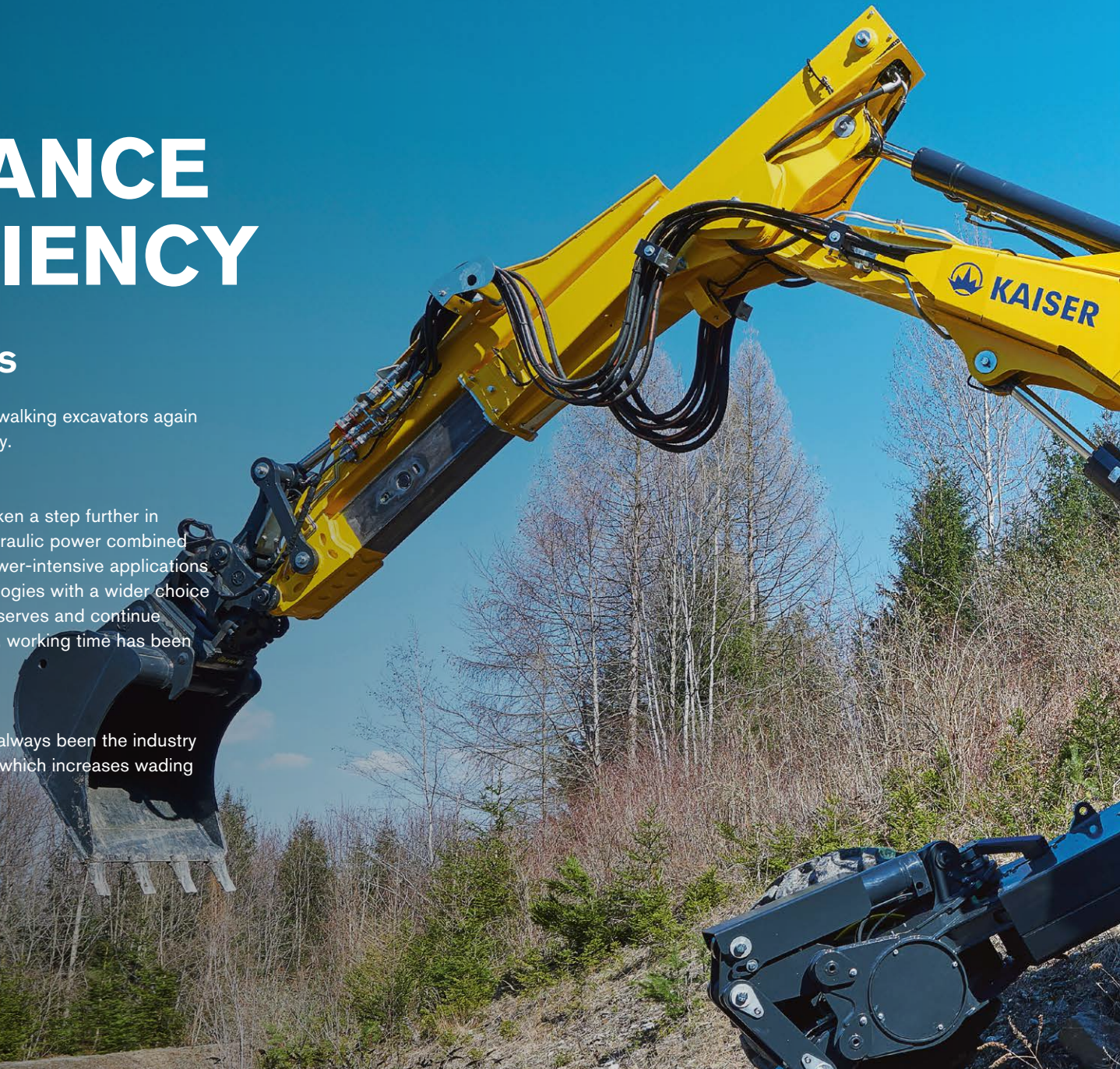



PERFORMANCE COUNTS WHEN

S12 ALLROAD

S10

Digging envelope KAISER S12 Allroad

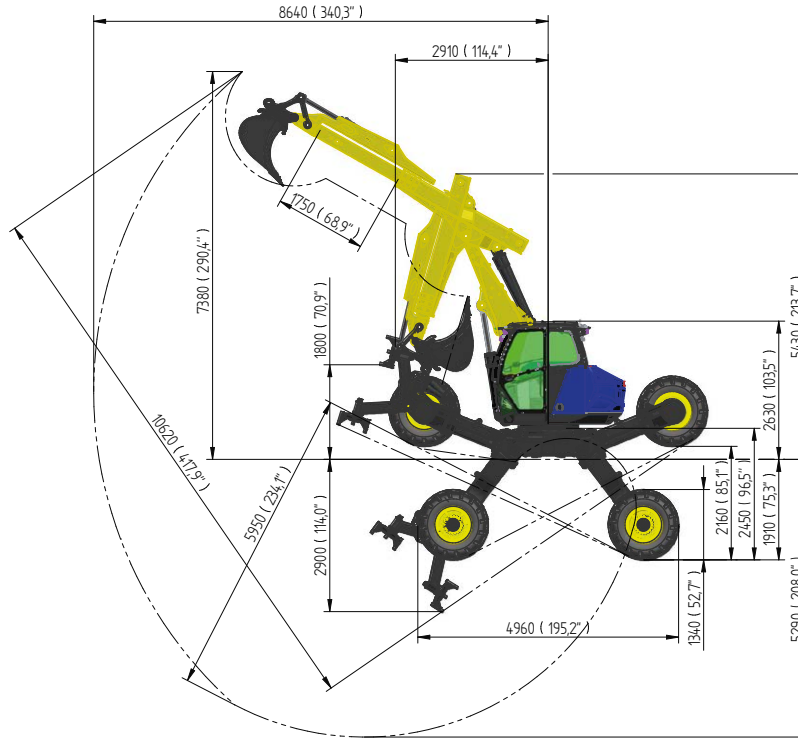

Digging envelope KAISER S10

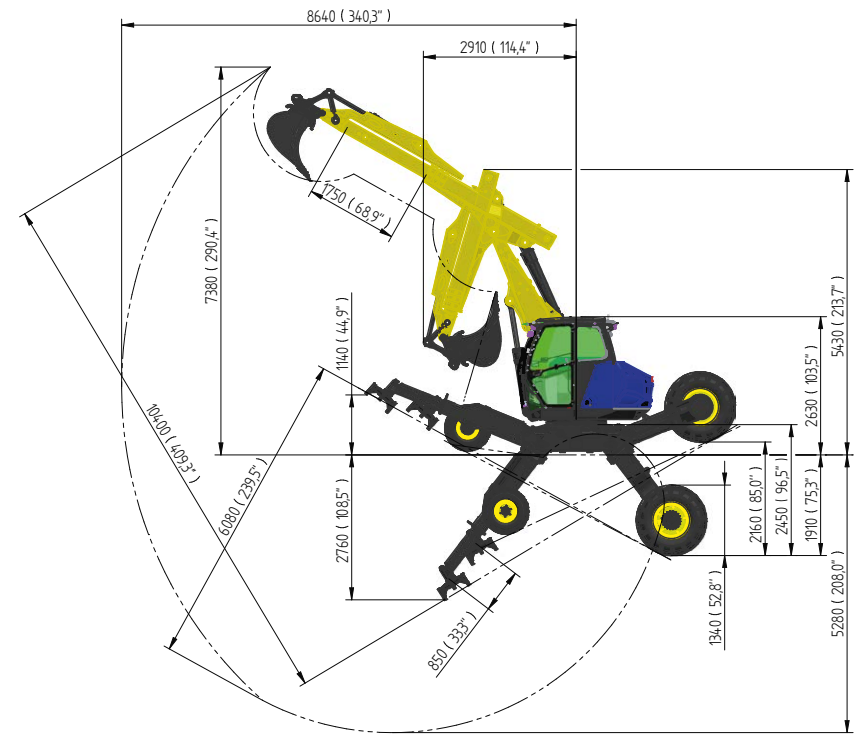

Undercarriage KAISER S12 Allroad

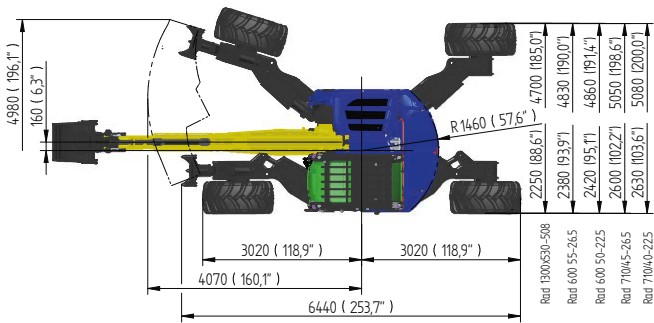

Undercarriage KAISER S10

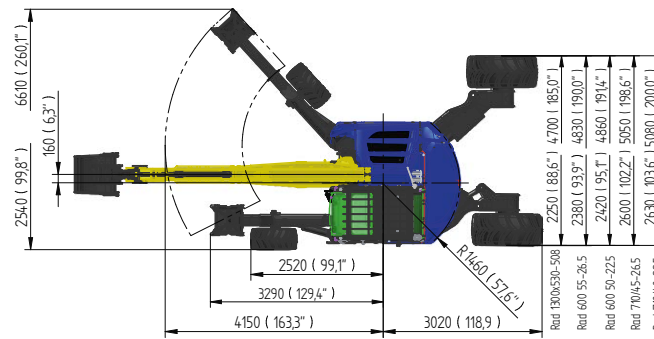

Turning radius KAISER S12 Allroad

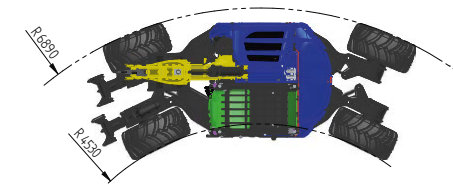

Turning radius KAISER S10

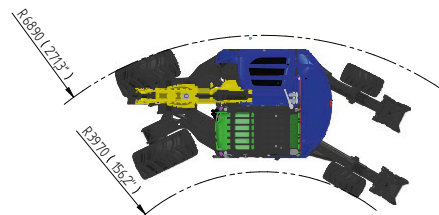

TECHNICAL SPECIFICATIONS S10/S12

Engine

HP engine model Perkins 1204J-E44TTA	Emissions Max. power Torque	EU2016/1628 Stage V; US EPA Tier 4 Final 140 kW / 190 hp @ 2000 rpm 815 Nm @ 1400 rpm
Perkins 1204J-E44TA	Emissions Max. power Torque	EU2016/1628 Stage V; US EPA Tier 4 Final 110 kW / 155 hp @ 2000 rpm 560 Nm @ 1400 rpm
Perkins 1104D-E44TA	Emissions Max. power Torque	EU97/68 Stage IIIA; US EPA Tier 3 106 kW / 144 hp @ 2000 rpm 558 Nm @ 1400 rpm
Voltage	24 V	
Displacement	4400 ccm	
Service interval	500 operating hours	
Diesel tank capacity (fuel tank / reserve tank)	390 l (140/250)	
Capacity AdBlue tank	19 liters	

Cab

Cab	ROPS ISO3471 / FOPS ISO3449 approved safety cab, upper windscreen assisted, integrated working light
Driver seat	Air-suspended comfort seat with lap belt GRAMMER air- suspended super comfort seat with headrest (option), four-point safety belts (option)
Air-conditioning	Central operating element for heating and air-conditioning (option)
Control	Joysticks on control carriers at seat
Camera	Rear and side view camera

Performance data

Lifting capacity	3 m 9500 kg 4 m 6600 kg 6 m 4000 kg
Breakout force (ISO6015)	111 kN
Ripping force (ISO6015)	78 kN
Wading depth of hydraulic undercarriage (option)	2.45 m
Travel speed	Variable, 0-15 km/h, Two-speed, 0-15 km/h, Dependent on model and tyre size
Weight S10	from 12,800 kg
Weight S12 Allroad	from 14,200 kg

Hydraulics

Flow rate, working pump	Max. 350 l/min 320 bar
Flow rate, drive pump	Max. 180 l/min 400 bar
Flow rate, fan pump	Max. 44 l/min 200 bar
Hydraulic system	Three-circuit LS / LUDV load-independent flow-sharing system, option of four-circuit system (ROTOline)
Pump control	Bosch Rexroth LUDV system with electronic power limiting controller, pressure cut-off
Mode selection	Three individually adjustable performance modes and driver profiles for efficient and environmentally friendly working
Speed setting	Stepless adjustment of setting over the entire speed range
Filters	Return filter 10 µm Fine filter 1 µm
Cooling system	3-circuit cooling system, coolers arranged one above the other with reversible fan drive for cleaning Stepless, hydraulically driven fan
Cylinders	With joint bearings Lift and dipper cylinder with pipe fracture safety valve (ISO8643) Undercarriage cylinder with pilot-controlled check valves
Circuit I	max. 180 l/min 120-320 bar
Circuit II	max. 40 l/min 120-320 bar
Circuit III (option)	max. 80 l/min 120-320 bar
ROTOline (option)	max. 220 l/min 100-350 bar
Quick coupler circuit	
Rope wind circuit, standard	max. 40 l/min 320 bar
Rope wind circuit, high flow	max. 100 l/min 320 bar
Return	
Leakage oil line (option)	

Swing system

Drive	Torque control in open circuit, radial piston motor with spring applied brake
Slewing speed	0 – 9 rpm, stepless
Slewing torque	57,000 Nm
Slewing ring	Module 10 with hardened surfaces
Brake	Negative holding brake, lockable



Liechtenstein, Austria, Italy,
Finland, Slovakia and the USA.

What does it mean to have 6
international production plants and
a network of over 100 sales
and service partners worldwide?

Customer proximity and regional
support!

THE RIGHT KAISER PRODUCT FOR YOUR APPLICATION

MOBILE WALKING EXCAVATOR



S10 and S12 stand for the latest generation of KAISER mobile walking excavators. They set benchmarks in performance and efficiency.

S12 Allroad



S10



The «power package» in the 10 t class.

S8



Proven toughness with the EU Stage IIIA engine generation.

S2



Perfectly matched to the application of the railway environment.

S22RR

VEHICLES FOR SEWER CLEANING AND INDUSTRIAL DISPOSAL



Recycling



Sewer cleaning



Water treatment



Dry vacuumation



Hydrovac

The international focus on modern environmental technologies has led to the growing importance of efficient, high-performance vehicles for sewer cleaning and industrial disposal. The KAISER Group is a leading player in the world market.