



TECHNICAL SHEET



TOP TANK HINGES

Description / Dimensions

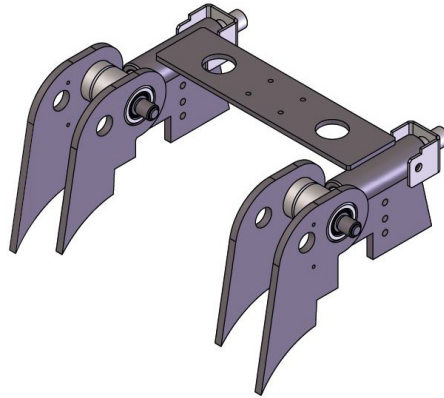

TOP TANK ADJUSTABLE HINGES

Top Tank Adjustable Hinges for Carbon steel and Stainless steel tanks.

They allow to recover the gape between the tank and the rear end, in order to always have a perfect seal.

TOP ADJUSTABLE HINGES FOR CARBON STEEL TANKS - from Ø 1000 mm to 1200 mm

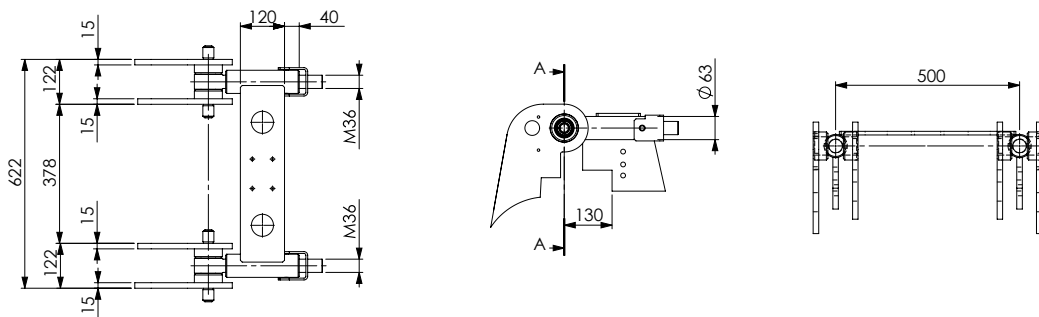

TOP ADJUSTABLE HINGES FOR CARBON STEEL TANKS - from Ø 1300 mm to 2100 mm

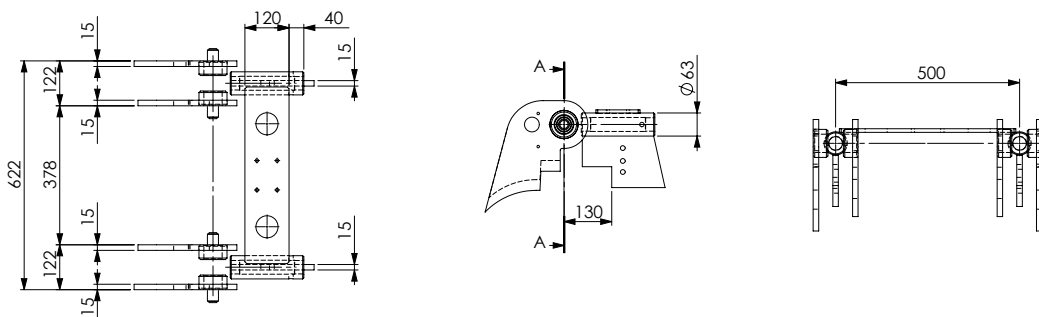

TOP ADJUSTABLE HINGES FOR STAINLESS STEEL TANKS - from Ø 1000 mm to 1200 mm

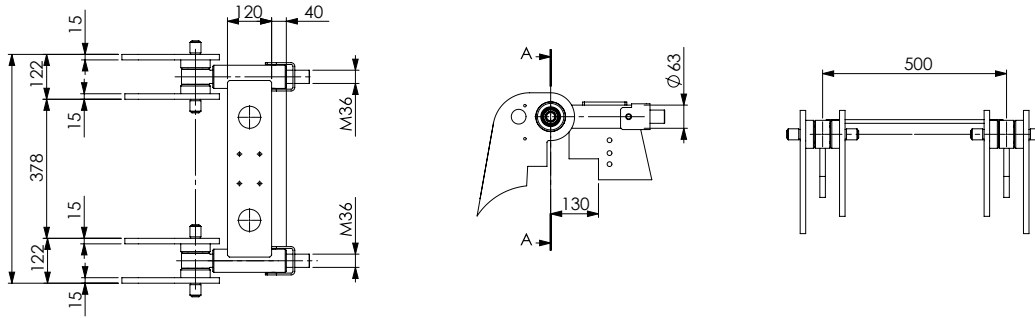

TOP ADJUSTABLE HINGES FOR STAINLESS STEEL TANKS - from Ø 1300 mm to 2100 mm

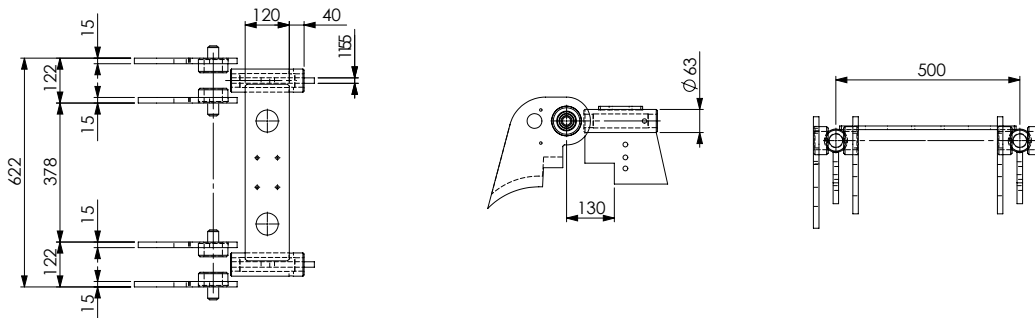

Technical data

Materials	Carbon steel and Stainless steel
Max tank pressure	4 bar (depending on the number of the rear door closing clamps)

Versions

description	code	weight
Hinges for Carbon steel tanks Ø1000-1200 mm	6.810006290-1C	43 kg
Hinges for Carbon steel tanks Ø1300-2100 mm	6.810003090-2C	49 kg
Hinges for Stainless steel tanks Ø1000-1200 mm	6.810001900-1C	50 kg
Hinges for Stainless steel tanks Ø1300-2100 mm	6.810003080-2	50 kg

Examples of application



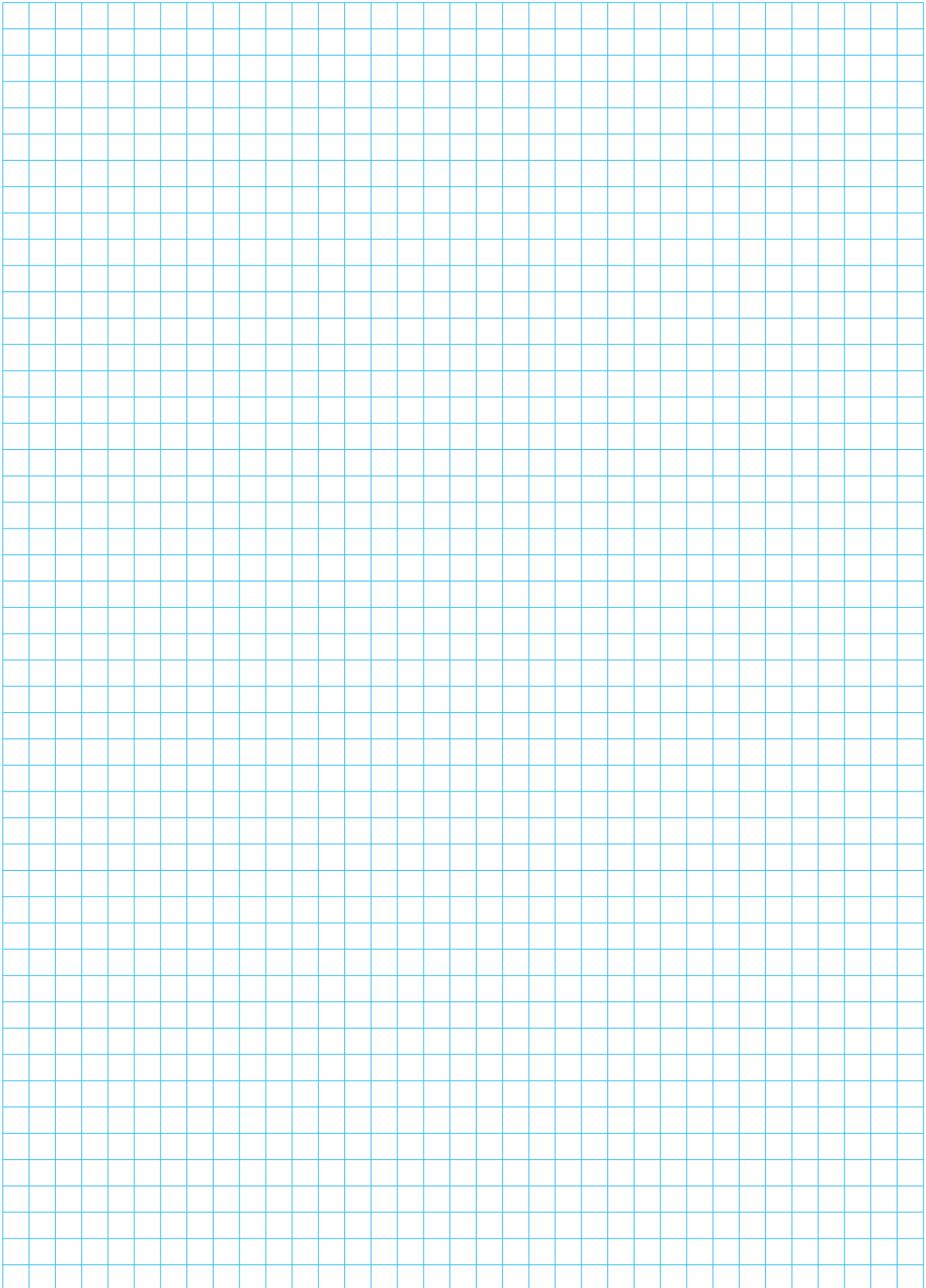



MORO KAISER **COMPONENTS**

MORO KAISER S.R.L.

Via Pontebbana, 16
33080 FIUME VENETO (PN) ITALY

Tel. 0434 951.211

Fax: 0434 957.786

infomoro@morokaiser.it